



PERMANENT MAGNETIC FILTERS

HPS & HPA MODELS



Applications

Machining:

- Broaching
- Gun Drilling
- Hobbing
- Milling

Grinding:

- Centerless ID & OD
- Thru-feed
- Cylindrical Roll
- Double Disc
- Creep Feed
- Thread

Honing

Micro Sizing

HIGH PERFORMANCE MAGNETIC FILTERS WITHOUT THE NEED FOR CONSUMABLE MEDIA

Flow Pro's Ferrite based Magnetic Filters are designed to provide the most efficient filtration at minimum cost. Our raised pole drum construction incorporates a 360° uninterrupted magnetic field. Each unit contains an adjustable automatic indexing control driven by Flow Pro's unique coolant level probe. The drum does not continually rotate. Dirty coolant entering the inlet of the magnetic filter flows across the solid magnetic drum. As the coolant flows against the drum, particles are attracted and held. Because the drum is not rotated continuously, the captured contaminants act as filter media to attract additional magnetic particles as well as non-magnetic particles such as wheel abrasives. Contaminants are discharged only when the drum is indexed resulting in drier particulates and less coolant loss. With this technology, these units can achieve 20 micron nominal coolant clarity and removal of over 99% of all grinding fines over twenty micron.

Phone: (815) 836-1900 Fax: (815) 836-1901

1000 W. Crossroads Pkwy Unit I Bolingbrook, IL 60490

WWW.FLOWPROINC.COM

FLOW PRO
PRODUCTS, INC.



PERMANENT MAGNETIC FILTERS

HPS & HPA MODELS

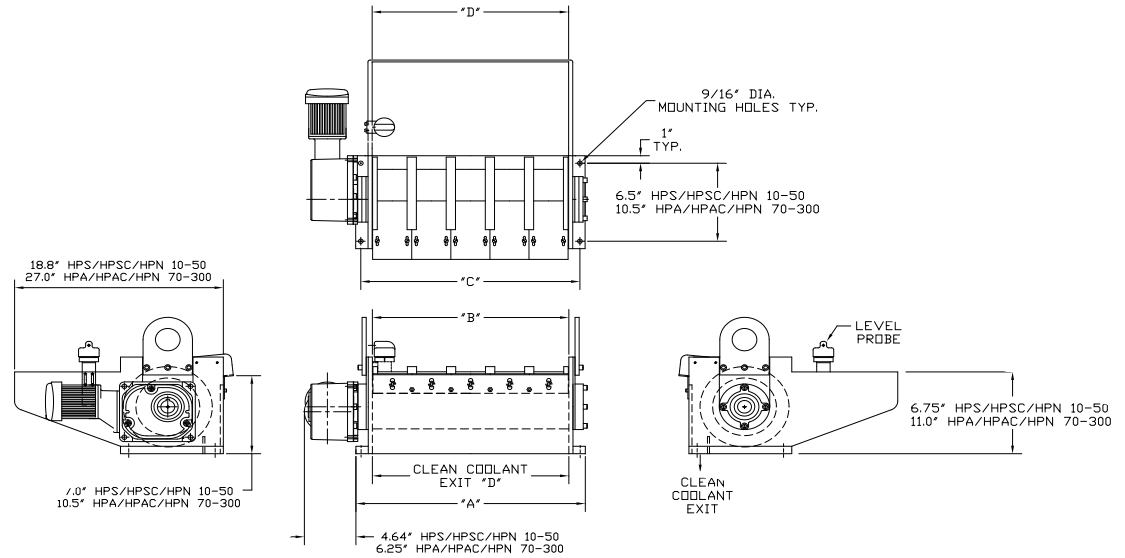

HPN-10 THRU HPN-50 IN DECIMALS OF AN INCH (MILLIMETERS)					
MODEL**	Flow Rate* (G.P.M.)	A	B	C	D
HPN-10	10	10.750 (273)	7.000 (178)	9.500 (241)	7.000 (178)
HPN-15	15	14.125 (359)	10.375 (264)	12.875 (327)	10.375 (264)
HPN-20	20	17.438 (443)	13.688 (348)	16.188 (411)	13.688 (348)
HPN-30	30	24.063 (611)	20.313 (516)	22.813 (579)	20.313 (516)
HPN-40	40	30.750 (781)	27.000 (686)	29.500 (749)	27.000 (686)
HPN-50	50	37.375 (949)	33.625 (854)	36.125 (918)	33.625 (854)
HPN-70 THRU HPN-300 IN DECIMALS OF AN INCH (MILLIMETERS)					
MODEL**	Flow Rate* (G.P.M.)	A	B	C	D
HPN-70	70	27.813 (706)	23.813 (605)	26.563 (675)	23.813 (605)
HPN-90	90	32.563 (827)	28.563 (725)	31.313 (795)	28.563 (725)
HPN-110	110	37.313 (948)	33.313 (846)	36.063 (916)	33.313 (846)
HPN-130	130	42.063 (1068)	38.063 (967)	40.813 (1037)	38.063 (967)
HPN-150	150	46.813 (1189)	42.813 (1087)	45.563 (1157)	42.813 (1087)
HPN-160	160	51.563 (1310)	47.563 (1208)	50.313 (1278)	47.563 (1208)
HPN-170	170	56.313 (1430)	52.313 (1329)	55.063 (1399)	52.313 (1329)
HPN-200	200	65.875 (1673)	61.875 (1572)	64.625 (1641)	61.875 (1572)
HPN-250	250	80.125 (2035)	76.125 (1934)	78.875 (2003)	76.125 (1934)
HPN-300	300	94.375 (2397)	90.375 (2296)	93.125 (2365)	90.375 (2296)

* Flow rates are based on water based coolant applications. Flow rates on oil applications are reduced by 50%.

** Suffix "C" on any model number represents "Chip Style Housing" for machining chip applications.

These dimensions are for general reference only and are not certified drawings

Phone: (815) 836-1900 Fax: (815) 836-1901

1000 W. Crossroads Pkwy Unit I Bolingbrook, IL 60490

WWW.FLOWPROINC.COM

FLOW PRO
PRODUCTS, INC.